

## Short Note

# Final-state interaction in spin asymmetry and GDH sum rule for incoherent pion production on the deuteron

E.M. Darwish<sup>a</sup>, H. Arenhövel<sup>b</sup>, and M. Schwamb

Institut für Kernphysik, Johannes Gutenberg-Universität, D-55099 Mainz, Germany

Received: 14 February 2003 / Revised version: 10 April 2003 /  
Published online: 1 July 2003 – © Società Italiana di Fisica / Springer-Verlag 2003  
Communicated by V. Vento

**Abstract.** The contribution of incoherent single-pion photoproduction to the spin response of the deuteron, *i.e.*, the asymmetry of the total photoabsorption cross-section with respect to parallel and antiparallel spins of photon and deuteron, is calculated over the region of the  $\Delta$ -resonance with inclusion of final-state  $NN$  and  $\pi N$  rescattering. Sizeable effects, mainly from  $NN$  rescattering, are found leading to an appreciable reduction of the spin asymmetry. Furthermore, the contribution to the Gerasimov-Drell-Hearn integral is explicitly evaluated by integration up to a photon energy of 550 MeV. Final-state interaction reduces the value of the integral to about half of the value obtained for the pure impulse approximation.

**PACS.** 11.55.Hx Sum rules – 13.60.Le Meson production – 24.70.+s Polarization phenomena in reactions – 25.20.Lj Photoproduction reactions

## 1 Introduction

The spin response or vector target asymmetry of the total photoabsorption cross-section of a hadron or nucleus has come into focus [1,2] with recent interest in the Gerasimov-Drell-Hearn (GDH) sum rule [3,4]. This sum rule connects the anomalous magnetic moment  $\kappa$  of a particle of mass  $M$ , charge  $eQ$ , and spin  $S$  with the energy-weighted integral over the difference  $\sigma^P(k) - \sigma^A(k)$  of the total photoabsorption cross-sections for circularly polarized photons on a target with spin parallel and antiparallel to the spin of the photon:

$$I^{\text{GDH}}(\infty) = \int_0^\infty \frac{dk}{k} (\sigma^P(k) - \sigma^A(k)) = 4\pi^2 \kappa^2 \frac{e^2}{M^2} S. \quad (1)$$

Here, the anomalous magnetic moment is defined by the total magnetic-moment operator of the particle  $\mathbf{M} = e(Q + \kappa)\mathbf{S}/M$ , where  $\mathbf{S}$  denotes the spin operator of the target.

For the deuteron, one finds a very small anomalous magnetic moment  $\kappa_d = -0.143$  resulting in a GDH prediction of  $I_d^{\text{GDH}} = 0.65 \mu\text{b}$ , which is more than two

orders of magnitude smaller than the nucleon values, *i.e.*,  $I_p^{\text{GDH}} = 204.8 \mu\text{b}$  for the proton and  $I_n^{\text{GDH}} = 233.2 \mu\text{b}$  for the neutron. The explicit evaluation of the spin asymmetry for various reaction channels, essentially photodisintegration and coherent and incoherent single-pion production, has shown that this small GDH sum rule value is the result of large cancellations between the contributions of the individual channels [5]. For photodisintegration alone one finds a large negative spin asymmetry close to the break-up threshold which arises from the large isovector  $M1$  transition to the resonant  $^1S_0$ -state. In fact, the explicit evaluation of the GDH integral for photodisintegration up to an energy of 550 MeV yields a large negative contribution of  $I_{\gamma d \rightarrow np}^{\text{GDH}}(550 \text{ MeV}) = -413 \mu\text{b}$ , which almost equals the sum of the GDH values of proton and neutron. We would like to remark that for this channel relativistic contributions were quite sizeable already at rather low energies below 50 MeV, reducing the GDH integral from  $-665 \mu\text{b}$  by about one third to the foregoing value. Furthermore, the GDH integral had already reached convergence at 550 MeV. In view of this negative contribution, a corresponding positive contribution has to be expected from the other channels, *i.e.*, mainly from pion photoproduction.

In this context it has been suggested to “measure”, in the absence of neutron targets, the neutron spin asymmetry by measuring the spin asymmetry of the deuteron

<sup>a</sup> Present address: Physics Department, Faculty of Science, South Valley University, Sohag, Egypt.

<sup>b</sup> e-mail: arenhoevel@kph.uni-mainz.de

for the pion photoproduction channels using a vector polarized-deuteron target, thus allowing the explicit evaluation of the GDH integral for the neutron. The implicit tacit assumption underlying this suggestion is that the contributions of pion production on proton and neutron in the deuteron add up incoherently. As was shown in [5], already for the impulse approximation this is not the case. With the present note we will demonstrate that it is even less fulfilled if final-state interaction effects are included.

Notwithstanding the “caveats” of such an “extraction” [6], it is certainly of interest to study the deuteron spin asymmetry for the pion production channels because in general polarization observables will give additional valuable information for checking the spin degrees of freedom of the elementary pion production amplitude of the neutron, provided that, and this is very important, one has under control all interfering interaction effects which prevent a simple extraction of this amplitude.

## 2 Final-state interaction in incoherent pion production on the deuteron

In our previous evaluation [5], the incoherent pion production contribution to spin asymmetry and GDH integral had been evaluated in the pure impulse approximation (IA) only, *i.e.*, by neglecting any final-state interaction effects (FSI) and possible two-body contributions to the production operator. In this framework, the reaction proceeds via the pion production on one nucleon, while the other nucleon acts merely as a spectator. In view of the dominance of the quasifree production process, one could expect that the IA would work reasonably well for charged-pion production. However, for neutral-pion production there is some double counting with respect to the coherent process due to the neglect of  $NN$  rescattering in the final state with the effect that the final state is not orthogonal to the  ${}^3S_1$ - ${}^3D_1$  state of the deuteron. Thus, in this case one expects a sizeable overestimation by the IA, because it contains a fraction of the coherent channel. This has been confirmed in [7,8], where FSI effects were considered, and a sizeable reduction of the unpolarized total and differential cross-sections of the incoherent neutral-pion production had been found due to the above-mentioned non-orthogonality, whereas for charged-pion production the FSI effects were significantly smaller.

In [8] we have included, besides the pure impulse approximation, the complete rescattering by the final-state interaction within each of the two-body subsystems  $NN$  and  $\pi N$ . For the pion the rescattering refers to the scattering on the spectator nucleon because the rescattering on the active nucleon is already included in the dominant elementary  $M_{1+}^{3/2}$  multipole. Therefore, the total transition matrix element reads in this approximation

$$\mathcal{M}^{(t\mu)} = \mathcal{M}^{(t\mu) \text{ IA}} + \mathcal{M}^{(t\mu) \text{ NN}} + \mathcal{M}^{(t\mu) \text{ } \pi N} \quad (2)$$

in an obvious notation. A graphical representation of the scattering matrix is shown in fig. 1. The necessary half-off-shell two-body scattering matrices were obtained from

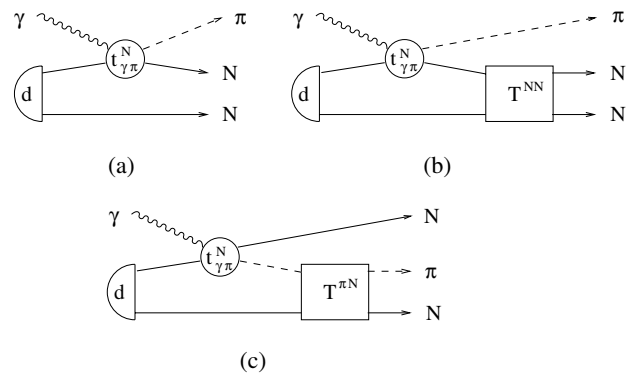

**Fig. 1.** Diagrammatic representation of  $\gamma d \rightarrow \pi NN$  including rescattering in the two-body subsystems of the final state: (a) impulse approximation (IA), (b)  $NN$  rescattering, and (c)  $\pi N$  rescattering.

separable representations of realistic  $NN$  and  $\pi N$  interactions which gave good descriptions of the corresponding phase shifts [9]. For  $NN$  rescattering, we have included all partial waves with total angular momentum  $J \leq 3$  and for  $\pi N$  rescattering  $S$ - through  $D$ -waves. As  $NN$  interaction we have used the Paris potential, but we have also tried the Bonn  $r$ -space potential, obtaining essentially the same result. For further details with respect to the rescattering contributions we refer to [8]. For the elementary pion photoproduction operator, we have taken, as in our previous work, the standard pseudovector Born terms and the contribution of the  $\Delta$ -resonance as described in detail in [10], and a satisfactory description of pion photoproduction on the nucleon in the  $\Delta$ -resonance region [8] was achieved.

The major effect of  $NN$  and  $\pi N$  rescattering in incoherent pion photoproduction on the deuteron was a reduction of the total unpolarized cross-section which amounts, in the maximum of the  $\Delta(1232)$ -resonance region for charged-pion photoproduction, to about 5 percent and to about 35 percent for  $\pi^0$  photoproduction. Thus for charged-pion production the IA appears to be a reasonable approximation within these five percent, but not for neutral-pion production, as already mentioned above. The dominant effect of FSI came from  $NN$  rescattering, whereas  $\pi N$  rescattering was much less important, almost negligible (compare the dashed curves with the solid ones in fig. 11 of [8], which are almost indistinguishable). With respect to experimental data a satisfactory agreement was achieved.

## 3 Results for spin asymmetry and GDH integral

In the meantime, we have evaluated also the spin asymmetry for these reactions. The results are presented in fig. 2, where the upper part shows the total photoabsorption cross-sections  $\sigma^P$  for circularly polarized photons on a target with spin parallel to the photon spin, the middle part  $\sigma^A$ , the one for antiparallel spins of photon and target and the lower part the spin asymmetry  $\sigma^P - \sigma^A$  for the

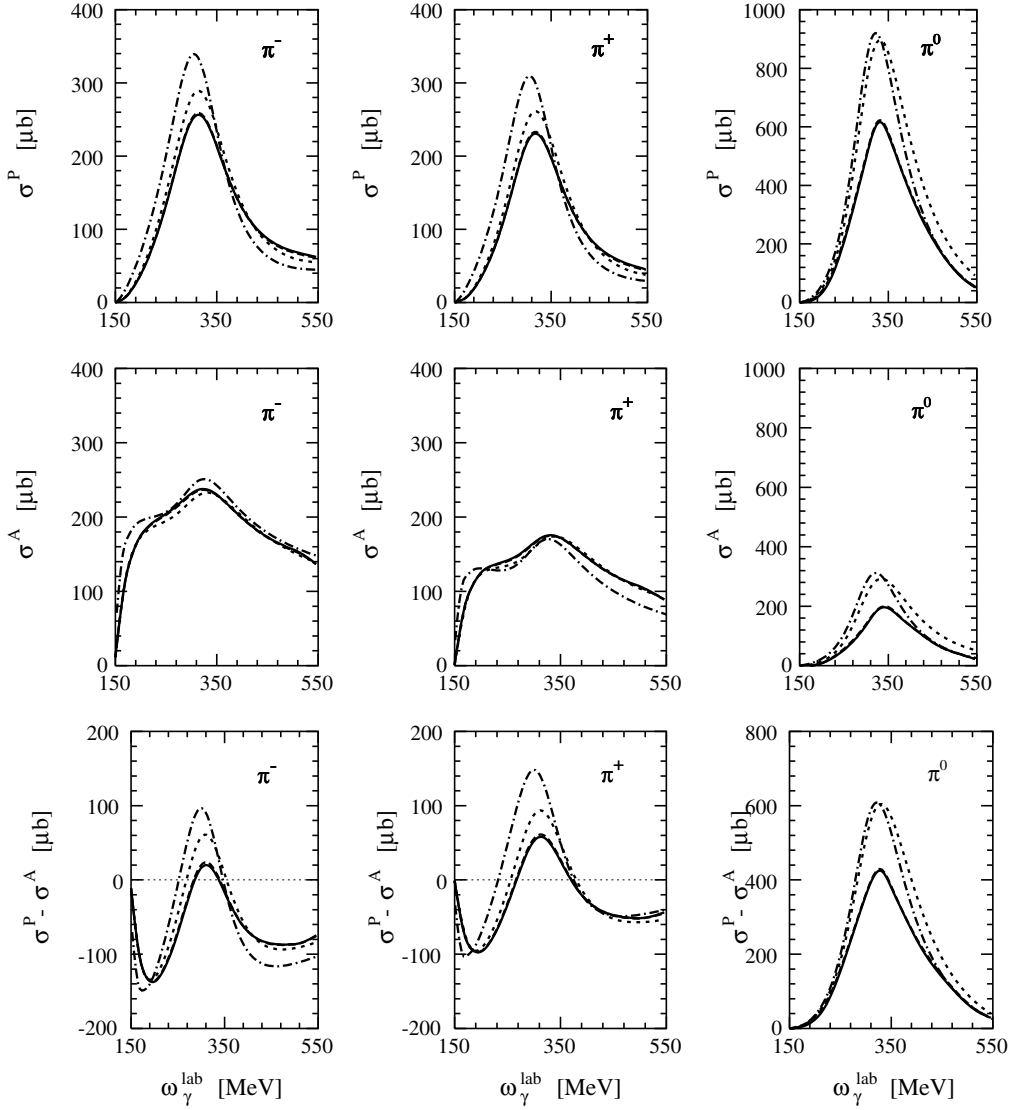

**Fig. 2.** Total absorption cross-sections for circularly polarized photons on a target with spin parallel  $\sigma^P$  (upper part) and antiparallel  $\sigma^A$  (middle part) to the photon spin. The lower part shows the difference  $\sigma^P - \sigma^A$ . Notation: dotted curves: impulse approximation (IA); dashed curves: IA +  $NN$  rescattering; solid curves: IA +  $NN$  +  $\pi N$  rescattering; dash-dotted curves: cross-sections for  $\pi^-$  production on the neutron (left panels),  $\pi^+$  on the proton (middle panels) and  $\pi^0$  on both, proton and neutron (right panels).

individual contributions of the different pion charge states to incoherent pion photoproduction on the deuteron. For comparison, we also show in the same figure the results on the free nucleon by the dash-dotted curves. In the case of  $\pi^0$ , it is the sum of the proton and neutron asymmetries.

One notes for the cross-sections  $\sigma^P$  and  $\sigma^A$  as well as for the spin asymmetry of the nucleons and the deuteron qualitatively a similar behaviour, although for the deuteron the maxima and minima are smaller and also slightly shifted towards higher energies. Furthermore, in  $\sigma^P$  the charged-pion contributions show a larger deviation between the IA and the elementary one, whereas for  $\sigma^A$  the differences are smaller. In contrast to this, one notes for the neutral pion contributions a much closer be-

haviour between the IA and the elementary reaction for both cross-sections and the difference.

FSI effects appear for charged-pion production mainly in  $\sigma^P$ , while for neutral pions they are of equal importance for both  $\sigma^P$  and  $\sigma^A$ , again because of the non-orthogonal final state in IA. The bottom panels in fig. 2 show that final-state interactions lead to an overall strong reduction of the spin asymmetry in the energy region of the  $\Delta(1232)$ -resonance. This reduction becomes about  $170 \mu\text{b}$  for  $\pi^0$  production and about  $35 \mu\text{b}$  for charged pions on the  $\Delta$ -peak. Thus, even for charged-pion production the IA is not anymore a reasonable approximation as it was for the unpolarized total cross-section. Moreover, already the IA deviates significantly from the corresponding nucleon

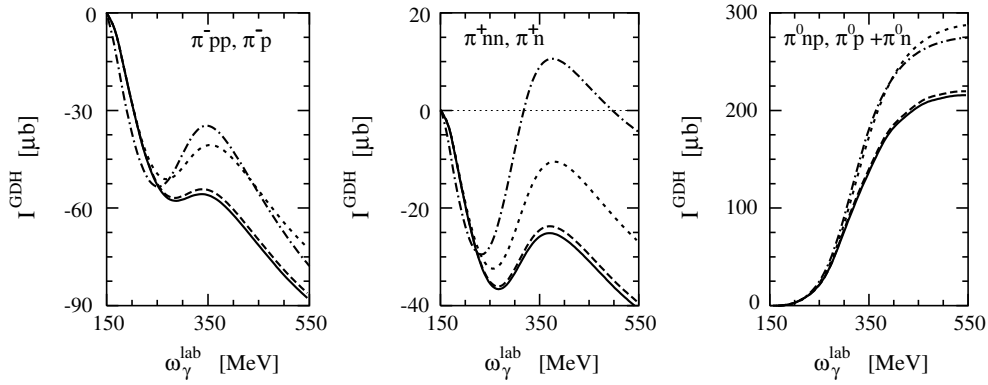

**Fig. 3.** The Gerasimov-Drell-Hearn integral as a function of the upper integration limit for the different channels of incoherent single-pion photoproduction on the deuteron and the nucleon. Notation of the curves as in fig. 2.

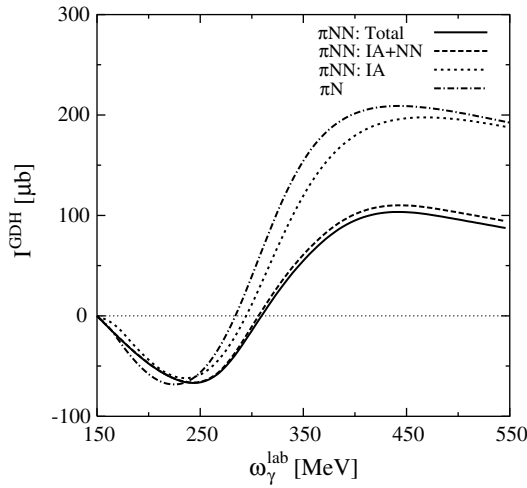

**Fig. 4.** Total contribution of the three channels of incoherent single-pion photoproduction to the GDH integral for the deuteron and the nucleon as a function of the upper integration limit. Notation of the curves as in fig. 2.

quantities for charged-pion production. These facts underline our doubts concerning an “extraction” of the neutron spin asymmetry from the one of the deuteron. It is also obvious that  $\sigma^P$  is much larger than  $\sigma^A$  because of the  $\Delta$ -excitation, in particular in the case of  $\pi^0$  production. The influence of FSI stems predominantly from  $NN$  rescattering, whereas  $\pi N$  rescattering is much smaller. In fact, the dashed curves, representing the inclusion of  $NN$ -FSI alone, and the solid ones with both  $NN$ - and  $\pi N$ -FSI appear almost indistinguishable. It is interesting to note that the size of the reduction of  $\sigma^P - \sigma^A$  in the IA by FSI for  $\pi^0$  production (about  $170 \mu\text{b}$  in the maximum), related to the already mentioned non-orthogonality effect, is comparable in magnitude, though somewhat larger, to the coherent contribution to the spin asymmetry of  $120 \mu\text{b}$  in the maximum as reported in [5].

In fig. 3 the corresponding GDH integrals are shown for the separate channels and in fig. 4 for the sum of all three pion channels as a function of the upper integration limit. One notes again the significant reduction by FSI, mainly

**Table 1.** Contributions of incoherent single-pion photoproduction to the GDH integral for the deuteron integrated up to 550 MeV in  $\mu\text{b}$ .

| Reaction                       | $I_{IA}^{\text{GDH}}$ | $I_{IA+NN}^{\text{GDH}}$ | $I_{IA+NN+\pi N}^{\text{GDH}}$ |
|--------------------------------|-----------------------|--------------------------|--------------------------------|
| $\gamma d \rightarrow pp\pi^-$ | -73                   | -87                      | -88                            |
| $\gamma d \rightarrow nn\pi^+$ | -27                   | -39                      | -41                            |
| $\gamma d \rightarrow np\pi^0$ | 287                   | 220                      | 216                            |
| $\gamma d \rightarrow \pi NN$  | 187                   | 94                       | 87                             |

through  $NN$  rescattering, but the  $\pi N$  rescattering effect is now distinguishable although still quite small (compare the dashed with the solid curves in figs. 3 and 4).

The values of the GDH integral up to 550 MeV for all three channels and their sum are listed in table 1. A sizeable positive contribution comes from  $\pi^0$  production, whereas the charged pions give a negative but—in absolute size—smaller contribution to the GDH value. The inclusion of  $NN$ -FSI reduces the total GDH integral to one half of the IA value which is then further reduced, but on a much smaller scale by  $\pi N$  rescattering. Furthermore, we would like to point out that the total value of the integral of  $87 \mu\text{b}$  is thus considerably smaller than the sum of the neutron and proton values for the present model of the elementary model, namely  $I_n^{\text{GDH}}(550 \text{ MeV}) + I_p^{\text{GDH}}(550 \text{ MeV}) = 197 \mu\text{b}$ . This underlines our caveat that a simple extraction of the neutron spin asymmetry from a measurement on the deuteron is not possible.

## 4 Concluding remarks

If one adds the previously reported values of the GDH integral from the photodisintegration channel ( $I_{\gamma d \rightarrow np}^{\text{GDH}}(550 \text{ MeV}) = -413 \mu\text{b}$ ) and the coherent pion production ( $I_{\gamma d \rightarrow \pi^0 d}^{\text{GDH}}(550 \text{ MeV}) = 63 \mu\text{b}$ ) from [5], one finds for the total GDH value from explicit integration up to 550 MeV a negative value  $I_d^{\text{GDH}}(550 \text{ MeV}) = -263 \mu\text{b}$

which has to be compared to the value  $I_d^{\text{GDH}}(\infty) = 0.65 \mu\text{b}$ . However, as was already mentioned in [5], the model of the elementary production amplitude above the  $\Delta$ -resonance is not very realistic, because it had been constructed primarily to give a realistic description of the  $\Delta$ -resonance region and not at higher energies. In fact, it grossly underestimates the GDH integral up to 550 MeV if we compare  $I_{n+p}^{\text{GDH}}(550 \text{ MeV}) = 197 \mu\text{b}$  of our model with the most recent MAID 2000 analysis [11] yielding a value  $I_{n+p}^{\text{GDH}}(550 \text{ MeV}) = 282 \mu\text{b}$ . The latter value is based on a multipole analysis of experimental pion photoproduction data. Thus it is clear that the large negative value for the deuteron will be reduced significantly using an elementary production operator which yields a better description above the  $\Delta$ -resonance. Moreover, the pion production contribution has not yet reached convergence at 550 MeV (see figs. 3 and 4). In fact, one expects at energies above 550 MeV further positive contributions from pion production [12]. Thus, for a more quantitative evaluation one has to use a more realistic elementary operator. In addition, an appropriate  $NN$  interaction model which includes retardation effects and inelasticities is needed as well as the consideration of relativistic effects which turned out to be very important for the spin asymmetry of the photodisintegration channel [5], as mentioned above. In addition, a genuine three-body approach would be desirable.

Thus, we would like to conclude that, notwithstanding the shortcomings of the present work, the results clearly show first of all the importance of final-state interaction effects in the spin asymmetry of the deuteron, a feature which certainly will remain true in a more realistic treatment of the energy region above the  $\Delta$ -resonance. Secondly, it is obvious that a measurement on the deuteron will not provide direct access to the spin asymmetry of the neutron. However, the deuteron spin asymmetry will certainly provide us with an important check observable for testing our knowledge of the pion photoproduction on

the neutron and thus will give us valuable information on the neutron's spin asymmetry in an indirect manner if one has a reliable model for the FSI and possible other two-body effects at hand for the analysis.

This work was supported by the Deutsche Forschungsgemeinschaft (SFB 443). E.M. Darwish acknowledges a fellowship from Deutscher Akademischer Austauschdienst (DAAD).

## References

1. D. Drechsel, *Prog. Part. Nucl. Phys.* **34**, 181 (1995).
2. D. Drechsel, L. Tiator (Editors), *Proceedings of the Symposium on the GDH Sum Rule, Mainz 2000* (World Scientific, Singapore, 2001).
3. S.B. Gerasimov, *Yad. Fiz.* **2**, 598 (1965); *Sov. J. Nucl. Phys.* **2**, 430 (1966).
4. S.D. Drell, A.C. Hearn, *Phys. Rev. Lett.* **16**, 908 (1966).
5. H. Arenhövel, G. Kreß, R. Schmidt, P. Wilhelm, *Phys. Lett. B* **407**, 1 (1997).
6. H. Arenhövel, in [2] p. 67.
7. M.I. Levchuk, M. Schumacher, F. Wissmann, *nucl-th/0011041*.
8. E.M. Darwish, H. Arenhövel, M. Schwamb, *Eur. Phys. J. A* **16**, 111 (2003).
9. E.M. Darwish, PhD Thesis, Johannes Gutenberg-Universität, Mainz, 2002.
10. R. Schmidt, H. Arenhövel, P. Wilhelm, *Z. Phys. A* **355**, 421 (1996).
11. D. Drechsel, O. Hanstein, S. Kamalov, L. Tiator, *Nucl. Phys. A* **645**, 145 (1999).
12. L. Tiator, in *Proceedings of the Second International Symposium on the Gerasimov-Drell-Hearn 2002 Sum Rule and the Spin Structure of the Nucleon, Genova, Italy, 3-6 July 2002*, edited by M. Anghinolfi, M. Battaglieri, R. De Vita (World Scientific, Singapore, 2003).